

SOME LIKE IT HOT



fahrenheit®

HT145ET



- Helios™ Additive reduces float current up to 75% enhancing high temperature life
- THT™ Plastic specifically formulated heat resistant plastic case and cover optimizes compression
- Microcat® Catalyst lowers float current, mitigates thermal buildup and cell dryout
- Exclusive IPF® Technology optimizes power capacity, cell consistency, and long-term reliability
- TempX™ Alloy inhibits corrosion under the highest temperature extremes

- Advanced AGM technology for superior power
- Puncture resistant micro-porous glass mat separators extend life
- Front access design for easy installation and maintenance
- Reinforced case resists bulging and meets safety requirements (UL 94 V-0)
- Case & cover heat sealed and 100% tested to prevent leaks
- Epoxy-sealed posts eliminate leaks
- Flame arresting, low pressure, self-sealing valves are 100% factory tested
- Computer-aided design and manufacturing control processes and standards to ensure quality products
- All batteries meet or exceed IEEE recommended practices
- Battery design and construction meet UL recognition requirements

SPECIFICATIONS

Nominal Voltage: 12-Volts

Rating: 140 Ampere-Hours @ 8 hr. rate to 1.75 V.P.C.

Positive Plate: >98% Pure lead with tin-calcium alloy

Negative Plate: Pure lead, calcium alloy

Post Seal: Epoxy-sealed

Terminal: Front access, 1/4" – 20 threaded insert

Case/Cover: Flame-retardant, THT™ – UL 94 V-0/>39% L.O.I.

Catalyst: Microcat®

Safety Vent: Low positive pressure, self-sealing w/flame arrestor

Float Voltage: 2.25 V.P.C. ± 0.01 V.P.C. @ 77°F (25°C)
Range: (13.44V to 13.56V per battery)

Design life: 12 years in float applications @ 77°F (25°C)

Dimensions: Length - 17.36" (440.9 mm)
Width - 6.90" (175.3 mm)
Height - 10.11" (256.7 mm)

Weight: 102 lbs. (46.3 kg)

DISCHARGE RATE IN AMPS @ 77°F (25°C)[†]

Volts per Cell (V.P.C.)	1 HR.	2 HR.	3 HR.	4 HR.	5 HR.	8 HR.	12 HR.	20 HR.	24 HR.
1.75	92.5	54.6	39.4	31.2	26.0	17.5	12.3	7.8	6.6
1.80	90.4	53.7	38.8	30.8	25.6	17.3	12.1	7.7	6.5
1.85	85.2	51.4	37.4	29.7	24.8	16.7	11.7	7.4	6.2
1.88	80.4	48.9	35.8	28.5	23.8	16.1	11.3	7.1	6.0
1.90	75.9	46.8	34.4	27.5	22.9	15.4	10.8	6.8	5.7

[†]Subject to change without notice.

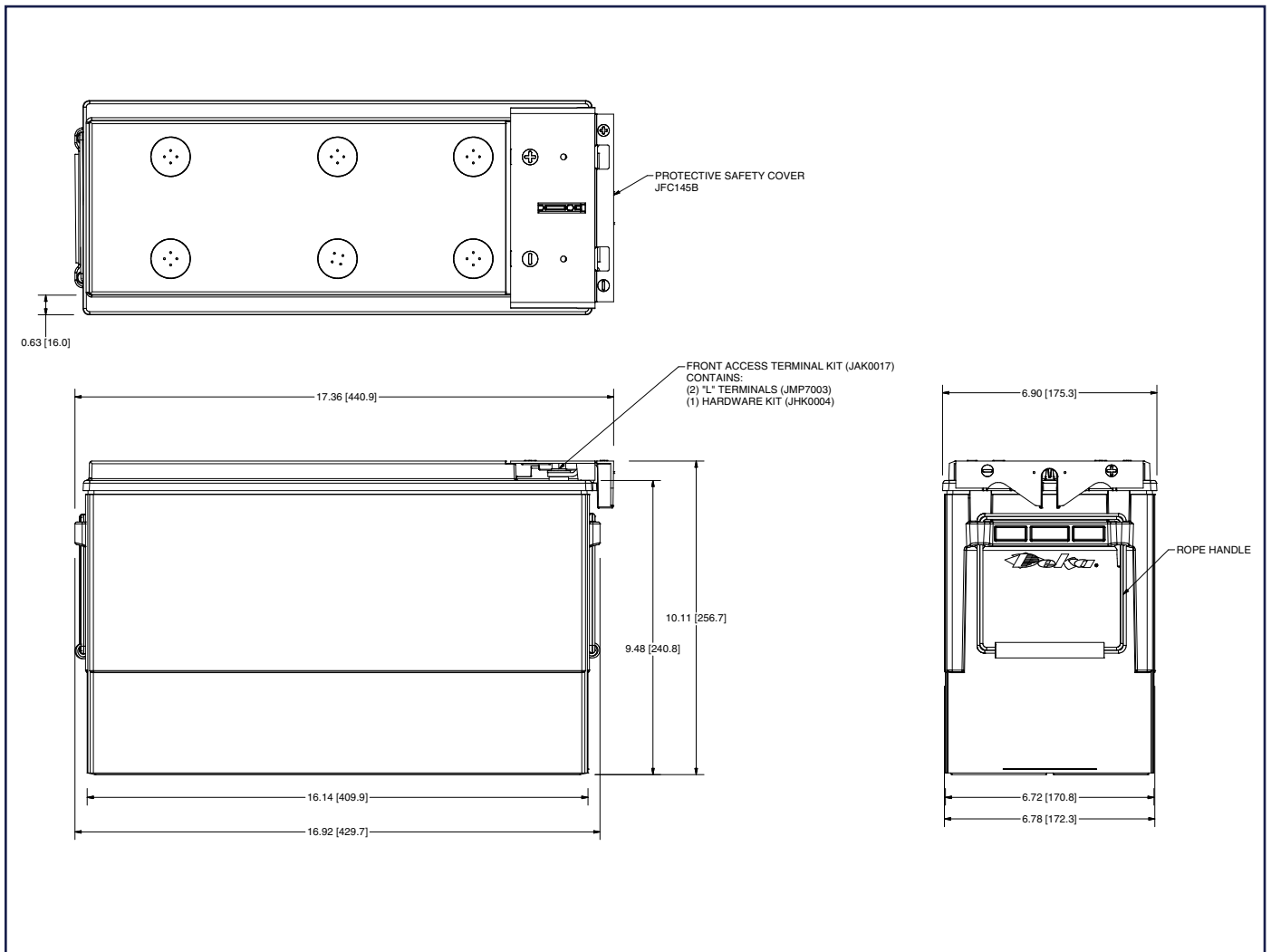

INSTALLATION AND OPERATING INSTRUCTIONS

<http://www.eastpenmanufacturing.com/wp-content/uploads/Fahrenheit-10-Manual-2100.pdf>

PROPOSITION 65 WARNING: Battery posts, terminals and related accessories contain lead and lead compounds, chemicals known to the State of California to cause cancer and reproductive harm. Batteries also contain other chemicals known to the State of California to cause cancer. **WASH HANDS AFTER HANDLING.**



www.dekabatteries.com

QUALITY SYSTEM
CERTIFIED
ISO 9001
IATF 16949
ENVIRONMENTAL
SYSTEM CERTIFIED
ISO 14001



East Penn Manufacturing Co.

Lyon Station, PA 19536-0147

Phone: 610-682-3263

Fax: 610-682-0891

e-mail: reservepowersales@dekabatteries.com