

# M40-12 SLD M

## SPECIFICATIONS

<b>Nominal Voltage (V)</b>	12V
<b>Nominal Capacity</b>	
20hour rate ( 2.25A to 10.50V )	45Ah
10hour rate ( 4.5A to 10.50V )	45Ah
5hour rate ( 7.65A to 10.20V )	38.25Ah
1C ( 45A to 9.60V )	20.25Ah
3C ( 135A to 9.60V )	16.2Ah
<b>Weight</b>	31.04 Lbs. (14.109 kg)
<b>Internal Resistance (at 1KHz)</b>	6 mΩ
<b>Maximum Discharge Current for 30 seconds :</b>	900A
<b>Maximum Discharge Current for 5 seconds :</b>	1800A
<b>Operating Temperature Range</b>	
<b>Charge</b>	0°C(32°F) to 40°C (104°F)
<b>Discharge</b>	-15°C(5°F) to 50°C (122°F)
<b>Storage</b>	-15°C(5°F) to 40°C (104°F)
<b>Charge Retention (shelf life) at 20°C (68°F)</b>	
1 month	92%
3 month	90%
6 month	80%
<b>Charging Methods at 25°C (77°F)</b>	
<b>Cycle use :</b>	Charging Voltage 14.4 to 15.0V Maximum Charging Current 13.5A
<b>Standby use :</b>	Float Charging Voltage 13.50 to 13.80V No current limit required
<b>Life expectancy :</b>	
<b>Cycle Use :</b>	100% depth of discharge 250 cycles 80% depth of discharge 350 cycles 50% depth of discharge 550 cycles
<b>Standby Use :</b>	3~5 years
<b>Case Material</b>	ABS (94-HB & 94V-0 flame retardant case)
<b>Terminal</b>	F4

## Maintenance-Free Rechargeable Sealed Lead-Acid Battery



## DIMENSIONS

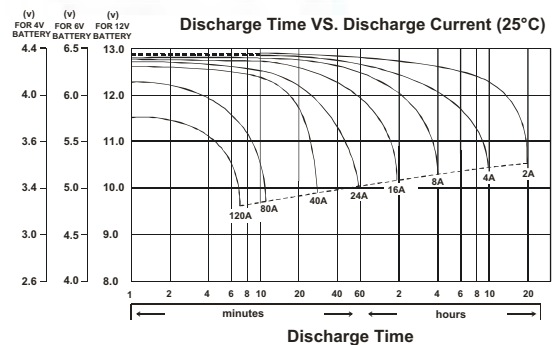
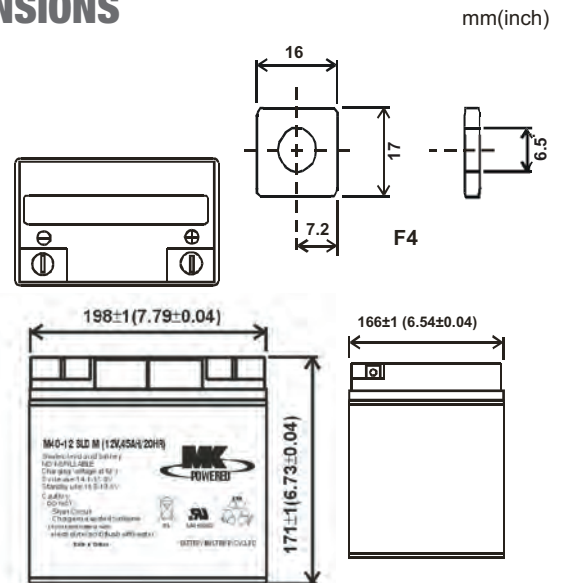

## MK Battery

1631 South Sinclair Street • Anaheim, California 92806  
Toll Free: 800-372-9253 • Fax: 714-937-0818 • E-Mail: sales@mkbattery.com

