

# ES12-12TE

## SPECIFICATIONS

<b>Nominal Voltage (V):</b>	12V
<b>Nominal Capacity:</b>	
20hour rate ( 0.6A to 10.50V )	12Ah
10hour rate ( 1.2A to 10.50V )	11.4Ah
5hour rate ( 2.04A to 10.20V )	10.2Ah
1C ( 12A to 9.60V )	8.4Ah
3C ( 36A to 9.60V )	6.12Ah
<b>Weight:</b>	9.39 Lbs. (4.27 kg)
<b>Internal Resistance (at 1KHz):</b>	9 mΩ
<b>Maximum Discharge Current for 30 seconds:</b>	240A
<b>Maximum Discharge Current for 5 seconds:</b>	480A
<b>Operating Temperature Range:</b>	
Charge	0°C(32°F) to 40°C (104°F)
Discharge	-15°C(5°F) to 50°C (122°F)
Storage	-15°C(5°F) to 40°C (104°F)
<b>Charge Retention (shelf life) at 20°C (68°F):</b>	
1 month	92%
3 month	90%
6 month	80%
<b>Charging Methods at 25°C (77°F)</b>	
Cycle use:	Charging Voltage 14.4 to 15.0V Maximum Charging Current 3.6A
Standby use:	Float Charging Voltage 13.50 to 13.80V
<b>Life expectancy</b>	
Cycle Use:	100% depth of discharge 225 cycles 80% depth of discharge 250 cycles 50% depth of discharge 750 cycles
Standby Use:	3~5 years
<b>Case Material:</b>	ABS (94-HB & 94V-0 flame retardant case)
<b>Terminal:</b>	F3

## Maintenance-Free Rechargeable Sealed Lead-Acid Battery



## DIMENSIONS

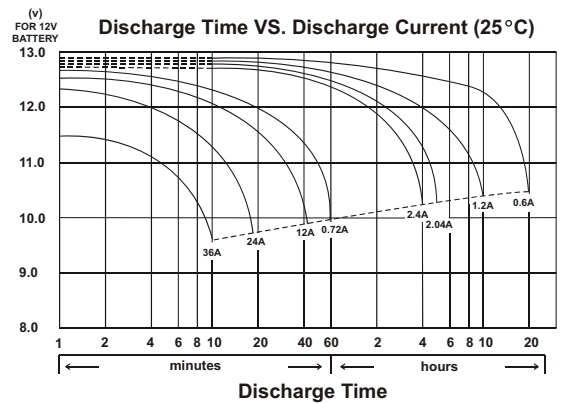
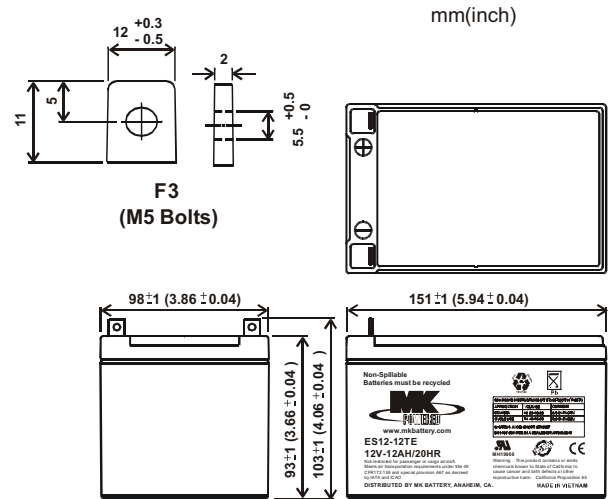

## MK Battery

1645 South Sinclair Street • Anaheim, California 92806  
Toll Free: 800-372-9253 • Fax: 714-937-0818 • E-Mail: sales@mkbattery.com

